

FRP Bridge Decks for Rural Communities

John F. Unser

VP Project/Program Manager
Composite Applications Group

CAG

COMPOSITE
APPLICATIONS
GROUP



**STRUCTURAL
COMPOSITES®**

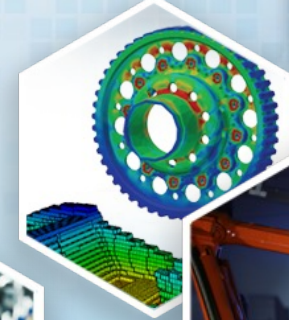

The Need

- ◆ The American Road & Transportation Builders Association (ARTBA) 2023 Bridge Report highlights that 1 in 3 US bridges needs repair or replacement and at the current rate it would take 68 years to fix all the nation's structurally deficient bridges.
- ◆ There are 20,177 bridges in Tennessee with 871 classified as structurally deficient.
- ◆ Rural communities have even more bridges that are not included in these numbers.



Bridge Location

- ◆ Located near Wartburg, TN
- ◆ Two lane road medium traffic
- ◆ Old bridge is 22 ft wide and 12 ft long
- ◆ Expanded the bridge to 25 ft wide and 16 ft long
- ◆ Bridge is part of a Y intersection and long vehicles need the extra width
- ◆ Longer length helps in flooding



The Technology

- ◆ Structural Composites FRP bridge deck using PRISMA technology
- ◆ Passed all AASHTO requirements
- ◆ Meets FHWA 100-year life span goal
- ◆ Prefabricated, lightweight for easy field installation
- ◆ Cost effective low installed cost and low maintenance
- ◆ Drop in place over steel girders

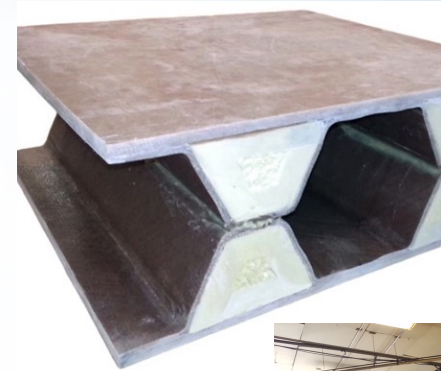

Bridge Deck Assembly

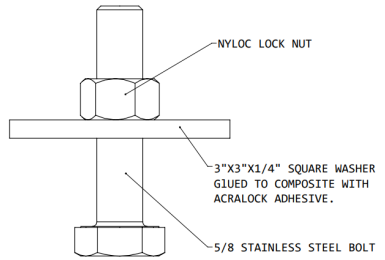
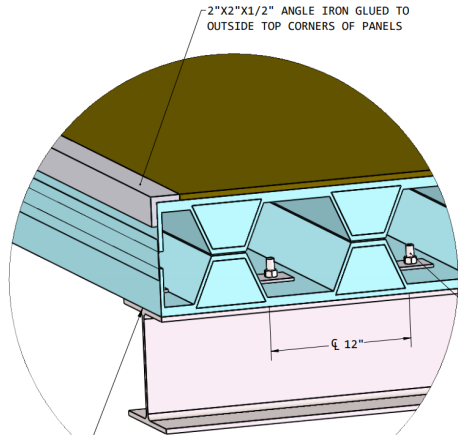
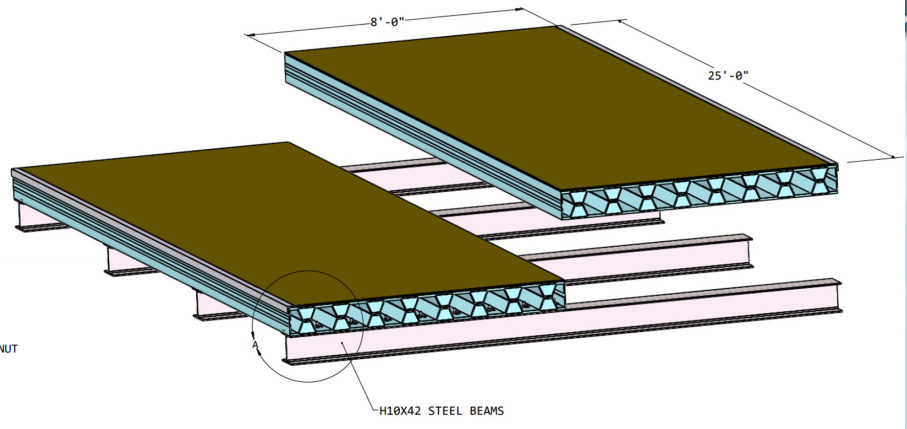

5/8 STAINLESS STEEL BOLTS THROUGH INNER FLANGE OF OUTER STEEL BEAMS

PRISMA PANELS ARE GLUED TO STEEL GIRDERS.

Fabrication Process



Laminate deck

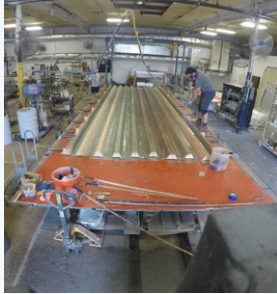

Install PRISMA



Apply adhesive



Bonding



Sensor install



Level rock



Apply Co-cure



Ship to site



Install (2 hours)

Morgan County Bridge



Structural Health Monitoring (SHM) System

Sensor Layout of High Definition Fiber Optic Sensor (HDFOS)

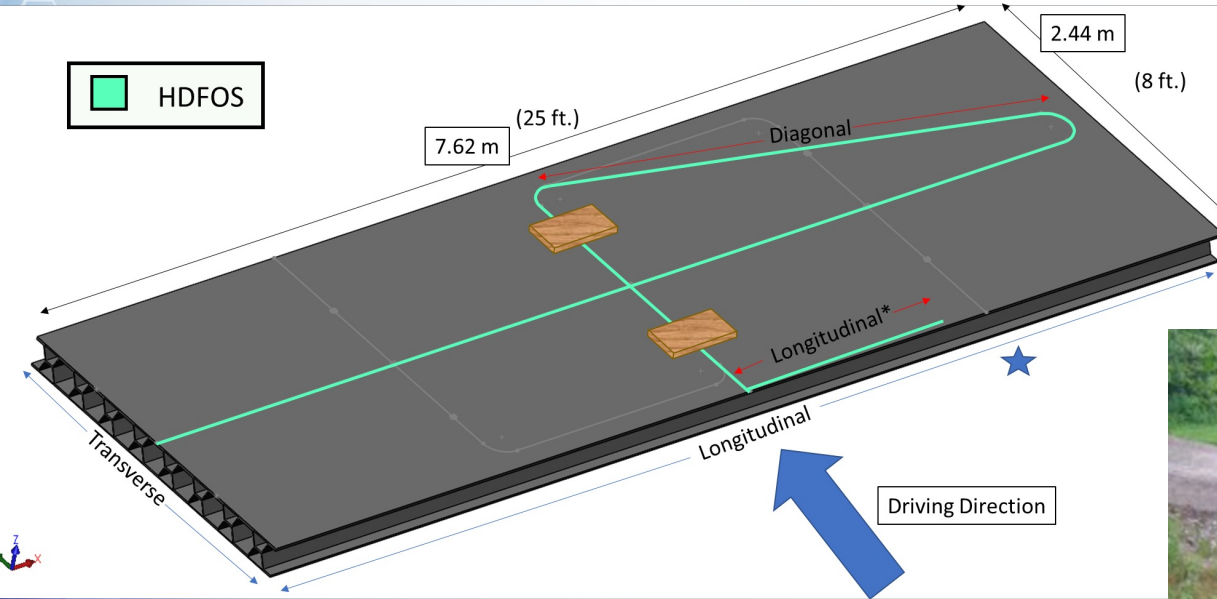

Additional Sensors:

- Accelerometer
- Magnetometer
- Temperature
- Relative humidity
- Deflectometer



Luna Innovations
University of Tennessee Knoxville

Live Camera

The Team



COMPOSITE APPLICATIONS GROUP

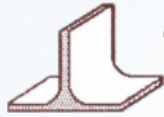

STRUCTURAL COMPOSITES

LUNA



THE COMPOSITES INSTITUTE
Advanced Composites Manufacturing Innovation



THE UNIVERSITY OF TENNESSEE
KNOXVILLE



McKinney's
EAST TENNESSEE'S PREMIER EXCAVATING SERVICES COMPANY

ACRA LOCK
ENGINEERED BONDING SOLUTIONS, LLC.

NEEL-SCHAFFER
Solutions you can build upon

Steffen Engineering Consulting

SUPERIOR
Chemicals - Composites - Recycling

COMPSYS Inc.

Structurally Superior

PRISMA
Composite Prelorms

www.PREFORMS.com

METEX
composites

STRENGTH. SUPPORT. SOLUTIONS.

WEST SYSTEM

INTERPLASTIC
CORPORATION



Joe Miller
Morgan County Road Superintendent

Summary

- ◆ AASHTO rated FRP composite bridge decks are available
- ◆ Benefits
 - ◆ Lighter, easier/faster to install
 - ◆ Installation cost neutral
 - ◆ Competitive BCA
 - ◆ Less maintenance cost
 - ◆ Longer life
 - ◆ Lower CO₂



Timelapse video (2 mins 27 seconds)
Morgan Co TN Composite Bridge Timelapse May 2021
<https://youtu.be/jMxUVUUfktI>

Ribbon Cutting video (3 minutes)
IACMI, Partners Launch High-Strength Composite “Smart Bridge” in Tennessee
<https://youtu.be/kzKpDdHrxjs>

Bridge overview (2 mins 47 seconds)
BRIDGING THE GAP – High tech composite bridge lays foundation for safe,
sustainable future
<https://youtu.be/tbJAFsfYxho>